

Environmental

**Klargester**

# Grease Traps & Separators

For the Effective Removal of Fats  
& Grease from Wastewater



*Sustainable, Reliable, Affordable*

  
**Kingspan**<sup>®</sup>

# Klargester Grease Traps & Separators

For the Effective Removal of Fats and Grease from Wastewater

## Applications

**Grease Traps:** An effective and hygienic method of separating fat and grease from waste water flow. Klargester grease traps will, by the removal of fat and grease:

- Greatly reduce incidents of blocked drains from catering establishments
- Improve the performance of septic tanks and field drains
- Prevent contamination of small sewage treatment plants

Grease traps are designed for small restaurants, public houses and canteens.

**Grease Separators:** For applications such as larger restaurants, hotels, etc. where a grease separator should be considered to give additional volume.

## Operation & Installation

Traps and separators allow fats and grease to naturally separate out from water, allowing their removal prior to the wastewater reaching the drainage system. The trap or separator should be installed close to the source of contamination before any foul waste can enter the drainage flow and to suit the expected liquid temperature.

For further information on this or any other product, please contact Klargester.

## Other Products

Klargester manufactures a wide range of pollution control equipment including:

- BioDisc® and Biotec™ Sewage Treatment Plants
- Envirosafe High Effluent Quality Treatment Systems
- HillMaster and Pumpstor24 Pump Systems
- Stormwater Attenuation Systems
- Septic Tanks
- Below Ground Storage Tanks
- Grease & Silt Traps
- Oil/Water Separators
- KingspanWater Rainwater Harvesting
- KingspanWater Garden Watering Systems

BioDisc® is a Registered Trademark of Kingspan Environmental.

Trap Model No.	Grease Capacity	Dimensions			Weight Empty/Full (kgs)
		A Length	B Width	C Height	
2	23	1330	850	1035	50/475
4	45	2070	1200	1335	120/1410

All dimensions in millimetres.

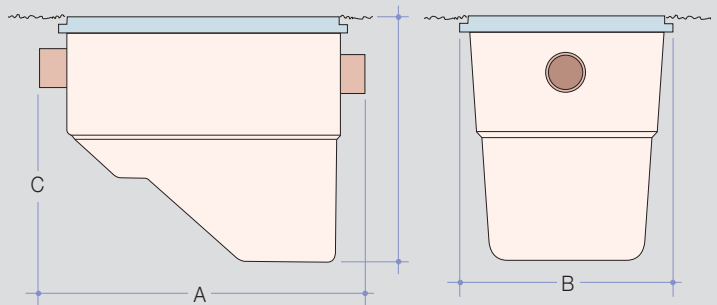

Separator Model	Dimensions		Working Capacity	Approx. Weight		Fall Across Unit
	A	B		Empty	Full	
G2B020	2210	1340	2000 litres	100kg	2200kg	50
G2B030	3060	2190	3000 litres	130kg	3180kg	50
G2B040	3910	3040	4000 litres	160kg	4160kg	50

All dimensions in millimetres. Larger sizes available on request.

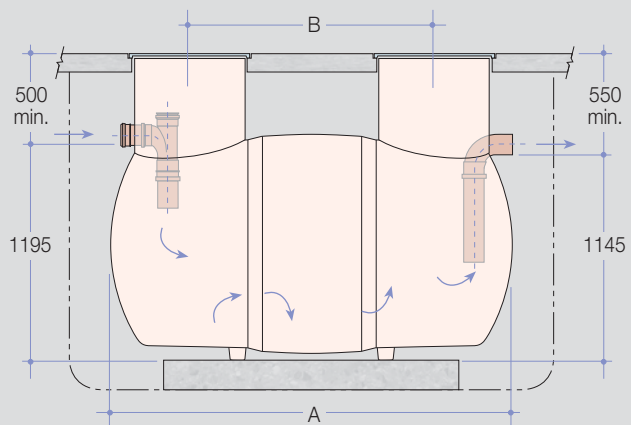

Issue No. 3: August 2010

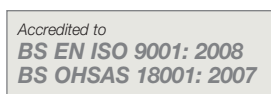

**Klargester**

UK: College Road North, Aston Clinton, Aylesbury, Buckinghamshire HP22 5EW  
 Tel: +44 (0) 1296 633000 Fax: +44 (0) 1296 633001  
 Scottish Office: Tel: +44 (0) 1355 248484  
 email: info@klargester.com

Ireland: Unit 1a, Derryboy Road, Carnbane Business Park, Newry, Co. Down BT35 6QH  
 NI Tel : +44 (0) 28 302 66799 Fax: +44 (0) 28 302 60046 ROI Tel: 048 302 66799 Fax: 048 302 60046  
 email: info@klargester.ie

Visit our website [www.klargester.com](http://www.klargester.com), or our company website [www.kingspanenv.com](http://www.kingspanenv.com)

